

Field Mounting Rate Totaliser

Model 202D

Features

- CENELEC, CSA_{USC} approved
- Displays Rate, Total and Accumulated Total
- Battery, Loop or DC powered
- Intrinsically safe version - 202Di
- Watertight to IP67 (Nema 4X)
- Wall, pipe, panel or flowmeter mounting
- Fully programmable
- 4-20mA output
- High & low alarms
- CE compliant



Overview

The 202D Field Mounting Rate Totaliser requires no external power and is designed to operate with turbine, positive displacement and paddlewheel flowmeters in applications such as irrigation systems and pipelines, and as a replacement for mechanical registers.

Battery, Loop or DC powered

The standard 202D is powered by long-life lithium batteries. Alternatively, the 202D can be loop powered via an optional 4-20mA output, or powered from a 9-28 Volts DC supply.

For installation in hazardous areas a certified intrinsically safe version is available. The intrinsic safety approvals cover a wide range of inputs and both the 4-20mA output and relay outputs.

Watertight field mounting enclosure

The 202D Rate Totaliser is housed in a rugged yet attractive IP67 (Nema 4X) rated polycarbonate enclosure which is completely watertight.

This enables the instrument to be mounted directly on the flowmeter, panel mounted or wall mounted using a special universal bracket. A 2" pipe mounting bracket is also available.

Fully user programmable

K-factor, decimal point positions, filter constants and time base are fully user programmable.

Rate and **Totals** can also be displayed in different engineering units such as gallons per minute and barrels.

Field Mounting Rate Totaliser

Model 202D

Frequency to Current conversion

The 202D loop powered Rate Totaliser makes an excellent **Frequency to Current** Converter particularly for low frequency inputs from positive displacement or turbine flowmeters.

Because the 202D calculates the flow rate by measuring the time interval between input pulses, it is able to provide a very stable and accurate 4-20mA output for low frequency inputs.

Time interval measurement also means that the 202D will have a fast response to changes in flow rate, although the response can also be limited, where necessary, via the digital filtering.

Digital filtering enhances rate accuracy

Frequency fluctuations caused by pulsating flow through a flowmeter, often makes the rate impossible to read with any precision.

The 202D has a digital filter which averages out these fluctuations and enables the rate to be read to a four digit accuracy.

The degree of filtering is fully programmable and, therefore, highly accurate and stable readings can be obtained without excessive lag. For versions with 4-20mA output, the current output is also filtered.

Versions Available

Battery powered

The battery version of the 202D is designed for operation where external power sources are not available. It derives its power from two lithium battery packs which provide sufficient power for up to 5 years.

Low battery power condition is signalled to the operator by a message on the LCD and battery replacement is easily carried out in the field even in hazardous areas.

4-20mA Output Loop powered

The 4-20mA output version draws its operating power from the 4-20mA loop and uses lithium batteries for back-up if the 4-20mA loop is interrupted.

The instrument provides a 2-wire re-transmission of the flow rate. Both the 4mA and 20mA points are fully programmable so that the output can span across the entire range or, alternatively, across a small section of the operating range.

DC powered

The DC powered version will operate from an external power source between 9 and 28 Volts and draws no more than 4mA. This enables the 202D to be powered from AC mains adaptors and eliminates the need to run mains voltages in the field.

Lithium batteries provide back-up if the DC power is interrupted.

Solid State Relay Outputs

Both the 4-20mA output version and the DC powered version are provided with two solid state relay outputs. The solid state relays provide high and low flow rate alarms or, alternatively, a pulse output and a low flow rate alarm. The outputs can sink up to 200mA and can be used to power external relays, audible alarms or counters. The outputs are internally protected against voltage spikes caused by relays and coils.

Both outputs are separately isolated via opto isolators.

The switching points can be programmed during the set-up mode. If programmed for a pulse output, the pulse can be selected as either unscaled (raw pulse input) or scaled. The maximum pulse frequency is 500mSec with a pulse width which is automatically set as:

1mSec if output > 50Hz
10mSec if output = 5...50Hz
100mSec if output < 5Hz

General

Display - Total	7 digit 10mm (0.4") high LCD (continuously powered). Note: The Resettable Total is resettable from the front panel and the Accumulated Total is displayed when the ACCUM TOT key is pressed.
Display - Rate	4 digit 8.5mm (0.33") high LCD (continuously powered).
K-factor Range	The pulses per unit of measure (eg. pulses/gallon) is programmable in the range 0.000001 to 999,999.
Decimal Points	Fully programmable for Rate and Total.
Time Base	Rates can be displayed in units per second, minute, hour or day.
Frequency Range	0.01Hz to 10kHz.
Signal Type	Switch settable for sine wave (15mV P-P minimum), open collector, reed switch or pulse.
Interference	CE compliance.

Physical

Operating Temperature	-20 to 60°C.
Enclosure	
Dimensions:	98mm (3.9") high x 152mm (6.0") wide x 43mm (1.7") deep.
Protection:	IP67 (Nema 4X) watertight.
Cable Entry:	By cable glands.
Materials:	Polycarbonate and ABS.
Mounting Options	
Wall:	Wall mount bracket with cable glands.
Pipe:	A galvanised metal bracket enables the 202D to be attached to a 2" vertical or horizontal pipe.
Panel:	Two mounting brackets are provided and terminals are accessible on the rear of the enclosure. Note that the panel mount version is not watertight.
Turbine Meter:	Bottom and rear mounting stems are available for mounting the 202D directly on turbine flowmeters which have a 1" NPT or BSP boss.

Battery Powered Version

Battery Type	2 x Lithium battery packs.
Battery Life	5 years.

Loop Powered 4-20mA Output Version

Scale	The 4mA and 20mA points are programmable.
--------------	---

Resolution & Linearity

	0.05% of span.
Accuracy	0.05% of span at 25°C.
Update Time	0.5s.
Connection	2 wire.
Voltage Across Output	28V dc maximum.
Voltage Drop	9V maximum.
Memory Backup	Lithium battery.

DC Powered / Alarm or Pulse Output Version

Outputs	2 x solid state relay outputs suitable for driving DC solenoids or external relays. The outputs provide fully programmable high & low flow alarms or a pulse output & low alarm.
Pulse Output	Scaled or unscaled pulse output, 500Hz maximum. Pulse width depends on output frequency and varies from 100mSec to 1mSec.
Switching Power	200mA, 30V dc maximum.
Saturation Voltage	0.8V dc across outputs when in the "on" state.
Isolation	Both outputs are separately isolated.
DC Power Input	9-28V @ 4mA maximum.
Memory Backup	Lithium battery.

Hazardous Area Approval (Model 202Di)

Type of Approval

CENELEC	EEx ia IIB T4.
CSA _{US/C}	Class 1, Groups C and D.
SAA	Ex ia IIB T6.

Maximum Ambient

60°C.

Maximum Input Parameters

(For certified IS coil or other certified IS sensors which produce a pulse output.)

U _o = 10.0V	Li = 0mH
I _o = 9.0mA	Ui = 24V
C(ext) = 60µF	Ii = 20mA
L(ext) = 1.5H	Pi = 320mW
	Ci = 0.002µF

Note: Devices such as reed switches, which can be classed as "Simple Apparatus" as defined in the Cenelec standard EN50020, can be connected to the Model 202D without additional certification.

Maximum Output Parameters

4-20mA or Relays	Ui = 28V
	Ii = 93mA
	Pi = 653mW

Important: Specifications are subject to change without notice.

Dimension Drawings

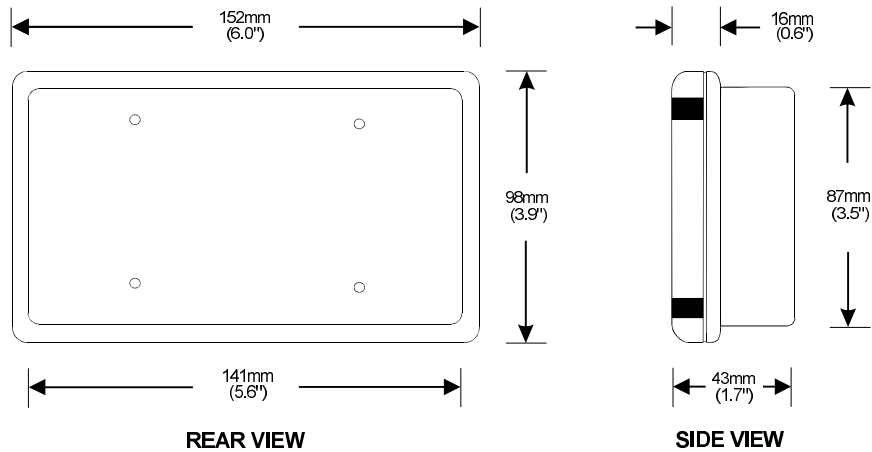

Terminal Descriptions

Terminals Common All Models	
No.	
7	Signal Input (-)
8	Signal Input (+)

4-20mA Output Versions	
No.	
1	4-20mA (-)
2	4-20mA (+)
3	Low Alarm (-)
4	Low Alarm (+)
5	High Alarm (-) or Pulse (-)
6	High Alarm (+) or Pulse (+)

DC Power Versions	
No.	
1	DC Power 0V
2	DC Power +9 to 28V dc

Ordering Information

When specifying please indicate model(s) required using the following method.

202D . 2 0
202Di . 4 3L

<p>Model</p> <p>Standard Rate Totaliser - 202D</p> <p>Intrinsically Safe Rate Totaliser - 202Di</p>	<p>Type of Power</p> <p>0 - Battery powered</p> <p>3L - DC powered with alarm/pulse outputs and battery back-up</p> <p>4L - Loop powered with 4-20mA output, alarm pulse output and battery back-up</p> <p>Type of Mounting</p> <p>0 - No cable entry holes</p> <p>1 - Panel mount</p> <p>2 - Wall mount with cable glands</p> <p>4 - Turbine flowmeter mount</p> <p>6 - 2" galvanised pipe bracket</p>
--	---

contrec

Distributed by:

Contrec Pty Ltd
22 Hall Street Hawthorn East, Melbourne 3123 AUSTRALIA
Tel: +61 3 9822 8966 Fax: +61 3 9822 8329
Email: contrec@contrec.com.au

Contrec - USA, LLC
916 Belcher Drive Pelham AL 35124 USA
Tel: (205) 685 3000 Fax: (205) 685 3001
Email: contrec@contrec-usa.com

Contrec Europe Limited
PO Box 436 Halifax HX1 2WG, UK
Tel: +44 1422 254 024 Fax: +44 1422 254 025
Email: sales@contrec.co.uk

Website: www.contrec.com.au